

Taking Spring-Return Actuation to the Next Level



# AS SERIES

## Spring-Return Pneumatic Valve Actuator

- Available in a “Compact” Model
- Thrusts up to 72,000 lbs
- SIL-3 Capable
- GT3 Triple Seal Gland for Severe Service Applications
- Fail-Close or Fail-Open
- Welding Certified to CSA 47.1 Division 2

# Fail-Open

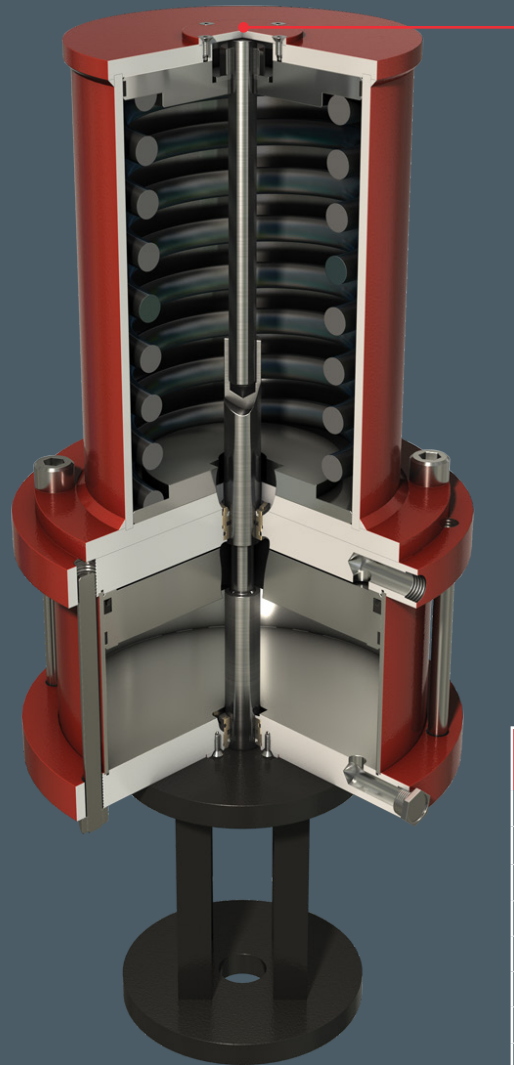

**Flange Cover** | Allows access to jam-nut to quickly and safely remove the canister for in-field service; Access for manual override available as an option

Material Breakdown	STANDARD	Corrosion Resistant
Head & Cap	A-36 hot rolled steel	316
Barrel (Air-Stage)	Composite	Composite
Piston 6-8"	Aluminum	Aluminum
Piston 10" & above	Mild Steel	Mild Steel
Piston Rod	1045	316
Gland	SAE 660	Delrin
Canister	Steel	316
Spring	High Strength Steel	High Strength Steel
Tie Rod 6"-10"	C12L14	316
Tie Rod 12" & above	ASTM A311B	17-4

# Specifications

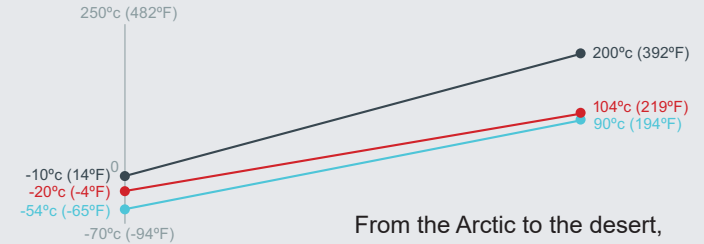

From the Arctic to the desert, proven seal compounds for a wide variety of applications.

- **Thrust: up to 72,000 lbs**
- **Bore size: 6" - 42"**
- **Configuration: Single-Stage and Tandem**
- **Stroke Range: Up to 24"**
- **Pressure Rating: 150 psi**
- **Rod Size: 1" to 5½"**
- **Welding Certified to CSA 47.1 Division 2**

## "Custom" now comes standard

- Choose from a full range of readily available dimensional sizes and thrusts
- Reduce design and development costs
- Faster, simpler selection process improves your project planning and turnaround on proposals, feasibility studies, etc.

## Safety comes first, stays first

- Springs are pre-compressed and factory-sealed inside a welded steel canister: no extended tie-rods required!
- Modular Canisters are easily and safely removed for simple in-field servicing of actuator piston seals

# Add-Ons

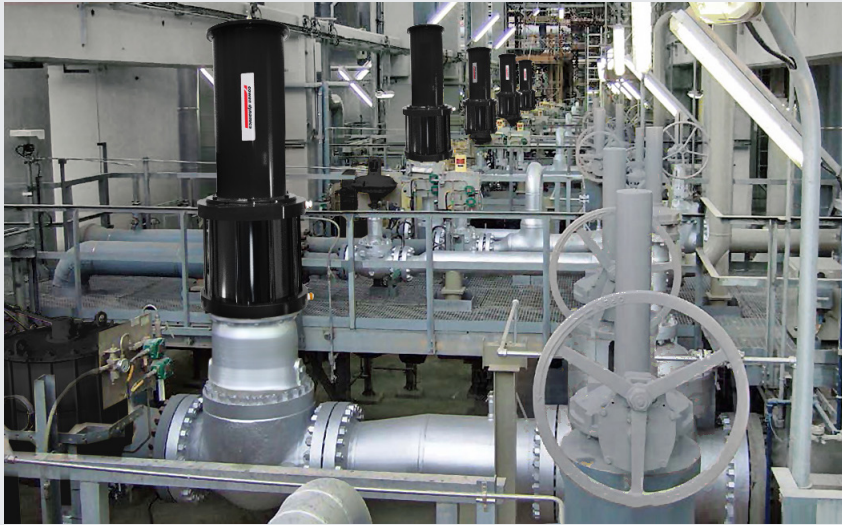

Fail-close AS Series on MP steam isolation valves in a HRSG at a US power plant

## Mounting Kits: ISO, MSS & Customized Patterns Available

Cowan valve mounting kits can be designed for any linear valve.  
Mounting kits available in steel and stainless steel construction.



**Anti-Rotation Torque Arm:**  
Maintains constant alignment between valve stem and cylinder piston-rod. Compatible with rotary type switch boxes and beacons.

**Field-Adjustable Travel Stops:**  
to limit stroke for position-seated or limited-travel applications. Ensures valve reaches positive sealing every time without damage to valve internals

## Automation Packages

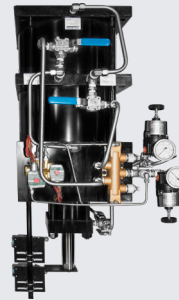

**Integration of Control Accessories:**  
Solenoid Valves  
Pilot Valves  
Quick Exhausts  
Positioners

**Position Feedback:**  
Limit switches and position sensors  
Field-adjustable for open and close indication.  
Analog and digital feedback

Ask about Cowan's new C-PAC Manifold solution!

## Gland Seals

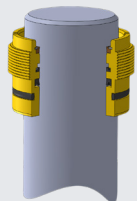

### GT3 Gland for Harsh Environments:

Triple-seal gland with dual wipers. Rugged metallic scraper and urethane double-acting wiper deflect contamination away from the rod seal for long service life.

- Low Temp available
- Cast iron construction for applications where yellow metals are not allowed

## Manual Overrides

Manual override options are available.



Screwjack with handwheel



Hydraulic manual override with indicator

# Compact Model: Fail-Close Data

Actuation Solutions and Systems for the World's Most Challenging Environments

Valve Stroke	Maximum Travel	ETC Preload	Available Force @ 60 psi						Available Force @ 80 psi						Available Force @ 100 psi						Spring Canister
			Bore	BTO	ETO	Bore	BTO	ETO	Bore	BTO	ETO	Bore	BTO	ETO	Bore	BTO	ETO				
(IN)	(IN)	(LBS)	(IN)	(LBS)	(LBS)	(IN)	(LBS)	(LBS)	(IN)	(LBS)	(LBS)	(IN)	(LBS)	(LBS)	(IN)	(LBS)	(LBS)	(IN)	(LBS)	(LBS)	(#)
2	2.75	300	7	1854	1277	8	2637	2059	7	2608	2031	8	3527	2950	7	3362	2785	8	4517	3939	6
	2.75	413	7	1730	1153	8	2413	1836	7	2484	1907	8	3403	2826	7	3238	2661	8	4393	3815	6
	2.75	525	7	1606	1028	8	2289	1712	7	2360	1782	8	3279	2701	7	3114	2536	8	4268	3691	6
	2.75	638	10	3764	3042	12	5768	5047	10	5305	4583	12	8001	7279	10	6846	6124	12	10233	9511	8
	2.75	750	10	3640	2918	12	5644	4922	10	5181	4459	12	7876	7154	10	6722	6000	12	10109	9387	8
	2.75	1000	10	3363	2642	12	5368	4646	10	4905	4183	12	7600	6878	10	6446	5724	12	9832	9110	8
	2.75	1180	10	3164	2443	12	5169	4447	10	4706	3984	12	7401	6679	10	6247	5525	12	9633	8911	8
	2.75	1360	12	4970	4104	14	7339	6472	12	7202	6336	14	10388	9521	12	9434	8568	14	13437	12570	10
3	3.75	550	10	3861	2876	12	5865	4881	10	5402	4418	12	8097	7113	10	6943	5959	12	10330	9345	8
	3.75	640	10	3761	2777	12	5766	4781	10	5302	4318	12	7998	7014	10	6844	5859	12	10230	9246	8
	3.75	730	10	3662	2677	12	5666	4682	10	5203	4219	12	7898	6914	10	6744	5760	12	10131	9146	8
	3.75	1000	10	3363	2379	12	5368	4383	10	4905	3920	12	7600	6616	10	6446	5461	12	9832	8848	8
	3.75	1180	12	5169	3988	12	5169	3988	12	7401	6220	14	10587	9405	12	9633	8452	14	13636	12454	10
	3.75	1513	12	4801	3620	14	7170	5989	12	7034	5852	14	10219	9038	12	9266	8085	14	13268	12087	10
	3.75	1963	14	6673	5491	16	9310	8129	14	9722	8541	16	13268	12087	14	12771	11590	16	17227	16045	12A
	3.75	2188	14	6424	5243	16	9061	7880	14	9473	8292	16	13020	11838	14	12522	11341	16	16978	15797	12A
	3.75	2638	14	5927	4214	16	8564	6851	14	8976	7263	16	12522	10809	14	12025	10312	16	16481	14768	12B
3.75	3177	14	5330	3618	16	7967	6255	14	8379	6667	16	11926	10213	14	11428	9716	16	15884	14171	12B	
4	4.75	820	10	3562	2315	12	5567	4320	10	5103	3857	12	7799	6552	10	6645	5398	12	10031	8784	8
	4.75	910	12	5467	3971	14	7836	6340	12	7699	6203	14	10885	9389	12	9932	8435	14	13934	12438	10
	4.75	1090	12	5268	3772	14	7637	6141	12	7501	6004	14	10686	9190	12	9733	8237	14	13735	12239	10
	4.75	1400	12	4926	3429	14	7294	5798	12	7158	5662	14	10343	8847	12	9390	7894	14	13393	11896	10
	4.75	1625	14	7046	5549	16	9683	8187	14	10095	8599	16	13641	12145	14	13144	11648	16	17600	16103	12A
	4.75	1963	14	6673	5176	16	9310	7814	14	9722	8226	16	13268	11772	14	12771	11275	16	17227	15730	12A
	4.75	2188	14	6424	3432	16	9061	6069	14	9473	6481	16	13020	10027	14	12522	9530	16	16978	13985	12C
	4.75	3042	14	5480	2487	16	8117	5124	14	8529	5536	16	12075	9083	14	11578	8585	16	16033	13041	12C
4.75	3582	16	7520	2532	18	10617	5630	14	7932	2944	16	11478	6491	14	10981	5993	16	15437	10449	12D	
5	5.75	3177	16	7967	1930	18	11065	5028	14	8379	2342	16	11926	5888	14	11428	5391	16	15884	9847	12D
	5.75	3582	16	7520	1482	18	10617	4580	14	7932	1894	16	11478	5441	14	10981	4943	16	15437	9399	12D
	5.75	4190	18	9945	3908	20	13305	7267	14	7260	1222	16	10806	4769	14	10309	4271	16	14765	8727	12D
	5.75	4676	20	12768	3530	22	16469	7232	18	14435	5197	20	18953	9715	16	14227	4990	18	19461	10224	12E
	5.75	5460	20	11901	2664	22	15602	6365	18	13568	4331	20	18086	8849	16	13361	4124	18	18595	9357	12E

FOR LEGEND, SEE NEXT PAGE

# Compact Model: Fail-Close Data

Actuation Solutions and Systems for the World's Most Challenging Environments

Valve Stroke	Maximum Travel	ETC Preload	Available Force @ 60 psi						Available Force @ 80 psi						Available Force @ 100 psi						Spring Canister
			Bore	BTO	ETO	Bore	BTO	ETO	Bore	BTO	ETO	Bore	BTO	ETO	Bore	BTO	ETO				
(IN)	(IN)	(LBS)	(IN)	(LBS)	(LBS)	(IN)	(LBS)	(LBS)	(IN)	(LBS)	(LBS)	(IN)	(LBS)	(LBS)	(IN)	(LBS)	(LBS)	(IN)	(LBS)	(LBS)	(#)
6	6.75	1400	14	7294	4211	16	9932	6848	14	10343	7260	16	13890	10807	14	13393	10309	16	17848	14765	12B
	6.75	1850	14	6797	3714	16	9434	6351	14	9846	6763	16	13393	10309	14	12895	9812	16	17351	14268	12B
	6.75	2232	16	9012	1924	18	12110	5022	14	9424	2336	16	12970	5883	14	12473	5385	16	16929	9841	12D
	6.75	2907	16	8266	1178	18	11363	4276	14	8678	1590	16	12224	5137	14	11727	4639	16	16183	9095	12D
	6.75	3380	20	14200	3356	22	17901	7058	16	11701	858	18	15867	5023	16	15660	4816	18	20894	10050	12E
	6.75	3920	20	13603	2760	22	17305	6461	18	15270	4427	20	19788	8945	16	15063	4219	18	20297	9453	12E
	6.75	4460	20	13007	2163	22	16708	5864	18	14674	3830	20	19192	8348	16	14466	3622	18	19700	8856	12E
	6.75	5852	22	15169	4325	24	19360	8516	18	13135	2291	20	17653	6809	16	12928	2084	18	18162	7318	12E
	6.75	6300	22	14674	3830	24	18865	8021	18	12640	1796	20	17158	6314	16	12433	1589	18	17666	6823	12E
	6.75	7380	22	13480	2636	22	13480	2636	20	15964	5120	22	20942	10098	18	16473	5629	20	22149	11305	12E
	6.75	8000	24	16986	6142	24	16986	6142	20	15279	4435	22	20256	9412	18	15787	4944	20	21464	10620	12E
	6.75	9800	24	14997	4153	26	19404	8560	22	18267	7423	24	23903	13059	18	13798	2954	20	19474	8631	12E
6.75	11600	26	17414	6570	28	22334	11490	24	21913	11070	26	27840	16997	22	23739	12895	24	30820	19976	12E	
8	8.75	2367	20	15320	1263	/	/	/	18	16987	2930	20	21505	7448	16	16780	2723	18	22013	7957	12E
	8.75	2637	20	15021	965	22	18723	4666	18	16688	2632	20	21206	7150	16	16481	2424	18	21715	7658	12E
	8.75	2840	20	14797	740	22	18498	4441	18	16464	2407	20	20982	6925	16	16257	2200	18	21491	7434	12E
	8.75	3380	22	17901	3845	24	22092	8035	18	15867	1810	20	20385	6328	16	15660	1603	18	20894	6837	12E
	8.75	4140	22	17061	3005	22	17061	3005	20	19545	5488	20	19545	5488	18	20054	5997	20	25730	11673	12E
	8.75	5220	22	15868	1811	22	15868	1811	20	18352	4295	20	18352	4295	18	18860	4803	20	24537	10480	12E
	8.75	5760	22	15271	1214	24	19462	5405	20	17755	3698	20	17755	3698	18	18263	4206	20	23940	9883	12E
	8.75	7100	24	17981	3924	24	17981	3924	20	16274	2217	20	16274	2217	18	16782	2725	20	22459	8402	12E
	8.75	8900	24	15991	1934	26	20398	6342	22	19262	5205	/	/	/	20	20469	6412	22	26723	12666	12E
	8.75	10700	26	18409	4352	28	23329	9272	22	17272	3215	24	22908	8851	20	18480	4423	22	24733	10677	12E
8.75	12931	30	26147	12090	22 TC	28983	14926	26	26369	12312	28	32986	18929	22	22268	8211	24	29349	15292	12E	
10	10.75	3500	24	21960	4690	24	21960	4690	20	20253	2983	20	20253	2983	18	20761	3491	20	26438	9168	12E
	10.75	4680	24	20655	3386	24	20655	3386	20	18948	1679	20	18948	1679	18	19457	2187	20	25133	7864	12E
	10.75	5300	22	15779	4492	24	19970	8683	20	18263	6976	/	/	/	18	18772	7484	20	24448	13161	12D
	10.75	6200	24	18975	7688	26	23383	12095	20	17268	5981	22	22246	10958	20	23453	12166	22	29707	18420	12D
	10.75	8800	28	25429	8159	30	30713	13443	26	30935	13665	28	37551	20281	24	33915	16645	26	41361	24091	12E
	10.75	11554	30	27669	10399	22 TC	30505	13235	28	34507	17238	/	/	/	26	38317	21048	28	46630	29360	12E
	10.75	14308	22 TC	27461	10191	24 TC	35843	18573	30	38570	21300	/	/	/	28	43586	26316	30	52515	35245	12E

**ETC Preload (End-to-Close Thrust)**

Force required to fully seat the valve under operating conditions  
 Must be greater than  $([\text{valve packing friction}] + [\text{valve seat friction}] + [\text{valve hydrostatic force}]) \times [\text{safety factor}]$

**ETO (End-to-Open Thrust)**

End-to-open; actuator available force at the end of the opening stroke  
 Must be greater than  $[\text{valve packing friction}]$

**BTO (Break-to-Open Thrust)**

Break-to-open; available force to 'crack-open' the valve when the actuator is fully extended  
 Must be greater than  $[\text{valve packing friction}] + [\text{valve seat friction}]$

*Stated thrust values are based on spring rates determined in accordance with ASTM A-125. Stated thrust values are for standard actuators only, if accessories are added, please consult factory.*

*Note - Consult Factory for larger actuators or Thrust values not shown here*

# Compact Model: Fail-Open Data

Actuation Solutions and Systems for the World's Most Challenging Environments

Valve Stroke	Maximum Travel	ETO Preload	BTO	Available force @ 60 psi				Available force @ 80 psi				Available force @ 100 psi				Spring Canister
				Bore	ETC	Bore	ETC	Bore	ETC	Bore	ETC	Bore	ETC	Bore	ETC	
(IN)	(IN)	(LBS)	(LBS)	(IN)	(LBS)	(IN)	(LBS)	(IN)	(LBS)	(IN)	(LBS)	(IN)	(LBS)	(IN)	(LBS)	(#)
2	2.75	300	823	8	1862	10	3406	7	1956	8	2851	7	2710	8	3841	6
	2.75	400	923	8	1751	10	3295	7	1846	8	2741	7	2600	8	3730	6
	2.75	525	1048	7	953	8	1613	7	1707	8	2603	7	2461	8	3592	6
	2.75	638	1160	7	829	8	1489	7	1583	8	2478	7	2337	8	3468	6
	2.75	750	1403	10	2764	12	4699	10	4305	12	6932	10	5846	12	9164	8
	2.75	1000	1653	10	2488	12	4423	10	4029	12	6655	10	5570	12	8888	8
	2.75	1180	1833	10	2289	12	4224	10	3830	12	6456	10	5371	12	8689	8
	2.75	1360	2013	10	2090	12	4025	10	3631	12	6258	10	5172	12	8490	8
	2.75	1540	2324	12	3682	14	5969	12	5914	14	9018	12	8146	14	12067	10
3	3.75	550	1441	10	2723	12	4658	10	4264	12	6890	10	5805	12	9123	8
	3.75	640	1531	10	2623	12	4559	10	4164	12	6791	10	5706	12	9023	8
	3.75	730	1621	10	2524	12	4459	10	4065	12	6691	10	5606	12	8924	8
	3.75	1000	1891	10	2225	12	4161	10	3767	12	6393	10	5308	12	8625	8
	3.75	1180	2071	10	2026	12	3962	10	3568	12	6194	10	5109	12	8426	8
	3.75	1513	2581	12	3397	14	5684	12	5630	14	8733	12	7862	14	11783	10
	3.75	1963	3031	12	2900	14	5187	12	5132	14	8236	12	7364	14	11285	10
	3.75	2188	3256	14	4938	16	7485	14	7987	16	11443	14	11036	16	15401	12A
	3.75	2638	4187	14	3909	16	6456	14	6958	16	10414	14	10008	16	14372	12B
	3.75	3177	4727	14	3313	16	5859	14	6362	16	9818	14	9411	16	13776	12B
4	4.75	820	1948	10	2162	12	4097	10	3703	12	6329	10	5244	12	8562	8
	4.75	910	2038	10	2062	12	3998	10	3604	12	6230	10	5145	12	8462	8
	4.75	1090	2444	12	3549	14	5836	12	5782	14	8885	12	8014	14	11935	10
	4.75	1400	2754	12	3207	14	5494	12	5439	14	8543	12	7671	14	11592	10
	4.75	1625	2979	12	2958	14	5245	12	5190	14	8294	12	7422	14	11343	10
	4.75	1963	3925	14	4199	16	6745	14	7248	16	10703	14	10297	16	14662	12B
	4.75	2188	4150	14	3950	16	6496	14	6999	16	10455	14	10048	16	14413	12B
	4.75	3042	5005	14	3006	16	5552	14	6055	16	9510	14	9104	16	13469	12B
	4.75	3582	6290	16	4132	18	7123	14	4635	16	8090	14	7684	16	12049	12C

FOR LEGEND, SEE NEXT PAGE

Note: it is the user's responsibility to ensure that final selection satisfies the application

Note: for forces other than shown, please consult factory

# Compact Model: Fail-Open Data

Actuation Solutions and Systems for the World's Most Challenging Environments

Valve Stroke	Maximum Travel	ETO Preload	BTO	Available force @ 60 psi				Available force @ 80 psi				Available force @ 100 psi				Spring Canister
				Bore	ETC	Bore	ETC	Bore	ETC	Bore	ETC	Bore	ETC	Bore	ETC	
(IN)	(IN)	(LBS)	(LBS)	(IN)	(LBS)	(IN)	(LBS)	(IN)	(LBS)	(IN)	(LBS)	(IN)	(LBS)	(IN)	(LBS)	(#)
5	5.75	3177	8640	18	4525	20	7769	16	5493	18	9552	14	5087	16	9451	12D
	5.75	3582	9045	18	4078	20	7321	16	5045	18	9104	14	4639	16	9004	12D
	5.75	4190	9653	20	6649	20	6649	16	4373	18	8432	16	8332	18	13459	12D
	5.75	4676	10139	20	6112	22	9686	18	7895	20	12297	16	7795	18	12922	12D
	5.75	5460	13818	22	5619	22	5619	20	8231	22	13081	18	8855	20	14416	12E
6	6.75	1400	3324	14	4864	16	7410	14	7913	16	11368	14	10962	16	15327	12A
	6.75	1850	4639	14	3410	16	5956	14	6459	16	9914	14	9508	16	13873	12B
	6.75	2232	5021	14	2987	16	5534	14	6036	16	9492	14	9085	16	13450	12B
	6.75	2907	9320	18	3774	20	7018	16	4741	18	8800	14	4335	16	8700	12D
	6.75	3380	9793	18	3251	20	6495	16	4219	18	8278	14	3812	16	8177	12D
	6.75	3920	13731	22	5715	24	9761	18	3924	20	8327	16	3824	18	8951	12E
	6.75	4460	14271	22	5118	24	9165	20	7730	22	12580	18	8354	20	13915	12E
	6.75	5852	15663	24	7626	26	11881	20	6191	22	11041	18	6816	20	12376	12E
	6.75	6300	16111	24	7131	26	11386	22	10546	24	16037	18	6320	20	11881	12E
8	8.75	2367	15085	22	4219	24	8265	18	2428	20	6830	16	2327	18	7454	12E
	8.75	2637	15355	22	3920	24	7966	20	6532	22	11381	18	7156	20	12717	12E
	8.75	2840	15558	22	3696	24	7742	20	6307	22	11157	18	6932	20	12492	12E
	8.75	3380	16098	22	3099	24	7145	20	5710	22	10560	18	6335	20	11895	12E
	8.75	4140	16858	24	6305	26	10561	20	4870	22	9720	18	5495	20	11055	12E

### ETO Preload (End-to-Open Thrust)

- End-to-Open; available spring force when the actuator is fully retracted
- Must be greater than [valve packing friction]

### ETC (End-to-Close Thrust)

- End-to-Close; actuator available force to seat valve
- Must be greater than ([valve packing friction] + [valve seat friction] + [hydrostatic force]) x [safety factor]

### BTO (Break-to-Open Thrust)

- Break-to-Open; available force to 'crack-open' the valve when the actuator is fully extended
- Must be greater than ([valve packing friction] + [valve seat friction]) x [safety factor]

*Note: it is the user's responsibility to ensure that final selection satisfies the application*

*Note: for forces other than shown, please consult factory*

# Standard Model: Fail-Close Data

Actuation Solutions and Systems for the World's Most Challenging Environments

Valve Stroke	Maximum Travel	ETC Preload	Available Force @ 60 psi						Available Force @ 80 psi						Available Force @ 100 psi						Spring Canister
			Bore	BTO	ETO	Bore	BTO	ETO	Bore	BTO	ETO	Bore	BTO	ETO	Bore	BTO	ETO				
(IN)	(IN)	(LBS)	(IN)	(LBS)	(LBS)	(IN)	(LBS)	(LBS)	(IN)	(LBS)	(LBS)	(IN)	(LBS)	(LBS)	(IN)	(LBS)	(LBS)	(IN)	(LBS)	(LBS)	(#)
2	2.75	300	6	1227	468	/	/	/	6	1777	1018	/	/	/	6	2327	1567	/	/	/	4
	2.75	413	6	1090	330	7	1682	923	6	1639	880	/	/	/	6	2189	1430	/	/	/	4
	2.75	525	7	1544	785	8	2228	1468	6	1502	743	/	/	/	6	2052	1292	/	/	/	4
	2.75	638	7	1407	648	8	2090	1331	6	1364	605	/	/	/	6	1914	1155	/	/	/	4
	2.75	750	7	1269	510	8	1953	1193	6	1227	468	7	2023	1264	6	1777	1017	/	/	/	4
	2.75	1000	8	1647	1042	10	3246	2641	7	1718	1113	8	2637	2032	7	2472	1867	/	/	/	6
	2.75	1180	8	1427	822	10	3026	2421	7	1498	893	8	2417	1812	7	2252	1647	/	/	/	6
	2.75	1360	8	1207	602	10	2806	2201	7	1278	673	10	4348	3743	7	2032	1427	8	3186	2581	6
	2.75	1540	10	2586	1981	12	4591	3986	8	1977	1372	10	4128	3523	7	1812	1207	8	2966	2361	6
3	3.75	550	7	1514	689	8	2197	1372	7	2268	1443	/	/	/	7	3022	2197	/	/	/	6
	3.75	640	7	1404	579	8	2087	1262	7	2158	1333	/	/	/	7	2912	2087	/	/	/	6
	3.75	730	7	1294	469	8	1977	1152	7	2048	1223	/	/	/	7	2802	1977	/	/	/	6
	3.75	1000	8	1647	822	10	3246	2421	7	1718	893	8	2637	1812	7	2472	1647	/	/	/	6
	3.75	1180	8	1427	602	10	3026	2201	7	1498	673	8	2417	1592	7	2252	1427	8	3406	2581	6
	3.75	1513	10	2620	1589	12	4624	3593	8	2010	979	10	4161	3130				8	3000	1969	8
	3.75	1963	10	2070	1039	12	4074	3043	10	3611	2580	/	/	/	8	2450	1419	10	5152	4121	8
	3.75	2188	12	3799	2768	14	6168	5137	10	3336	2305	12	6032	5000	10	4877	3846	/	/	/	8
	3.75	2638	12	3249	2218	14	5618	4587	10	2786	1755	12	5482	4450	10	4327	3296	12	7714	6683	8
	3.75	3177	12	2590	1353	14	4959	3721	12	4822	3585	14	8008	6770	10	3668	2430	12	7055	5817	10
4	4.75	820	8	1867	822	10	3466	2421	7	1938	893	8	2857	1812	7	2692	1647	/	/	/	6
	4.75	910	8	1757	712	10	3356	2311	7	1828	783	8	2747	1702	7	2582	1537	/	/	/	6
	4.75	1090	8	1537	492	10	3136	2091	8	2527	1482	10	4678	3633	7	2362	1317	8	3516	2471	6
	4.75	1400	10	2758	1451	12	4762	3456	8	2148	842	10	4299	2992	8	3137	1831	/	/	/	8
	4.75	1625	10	2483	1176	12	4487	3181	10	4024	2717	/	/	/	8	2862	1556	10	5565	4259	8
	4.75	1963	10	2070	764	12	4074	2768	10	3611	2305	12	6307	5000	8	2450	1144	10	5152	3846	8
	4.75	2188	12	3799	2493	14	6168	4862	10	3336	2030	12	6032	4725	12	8264	6958	/	/	/	8
	4.75	3042	12	2755	1188	14	5124	3556	12	4987	3420	14	8173	6605	10	3833	2265	12	7220	5652	10
	4.75	3582	14	4464	2896	16	7101	5533	12	4327	2760	14	7513	5945	12	6560	4992	/	/	/	10
5	5.75	3177	14	4959	3061	16	7596	5698	12	4822	2925	14	8008	6110	12	7055	5157	/	/	/	10
	5.75	3582	14	4464	2566	16	7101	5203	12	4327	2430	14	7513	5615	12	6560	4662	/	/	/	10
	5.75	4190	16	6358	4460	18	9455	7558	14	6770	4872	16	10316	8419	14	9819	7921	/	/	/	12A
	5.75	4676	16	5764	3012	18	8861	6110	14	6176	3424	16	9722	6971	14	9225	6473	/	/	/	12B
	5.75	5460	18	7903	5152	20	11263	8511	14	5218	2466	16	8764	6013	14	8267	5515	16	12722	9971	12B

### ETC Preload (End-to-Close Thrust)

Force required to fully seat the valve under operating conditions  
 Must be greater than [(valve packing friction) + (valve seat friction)  
 + (valve hydrostatic force)] x [safety factor]

### ETO (End-to-Open Thrust)

End-to-open; actuator available force at the end of the opening stroke  
 Must be greater than [valve packing friction]

### BTO (Break-to-Open Thrust)

Break-to-open; available force to 'crack-open' the valve when the actuator is fully extended  
 Must be greater than [valve packing friction] + [valve seat friction]



# Standard Model: Fail-Close Data

Actuation Solutions and Systems for the World's Most Challenging Environments

Valve Stroke	Maximum Travel	ETC Preload	Available Force @ 60 psi						Available Force @ 80 psi						Available Force @ 100 psi						Spring Canister
			Bore	BTO	ETO	Bore	BTO	ETO	Bore	BTO	ETO	Bore	BTO	ETO	Bore	BTO	ETO				
(IN)	(IN)	(LBS)	(IN)	(LBS)	(LBS)	(IN)	(LBS)	(LBS)	(IN)	(LBS)	(LBS)	(IN)	(LBS)	(LBS)	(IN)	(LBS)	(LBS)	(IN)	(LBS)	(LBS)	(#)
6	6.75	1400	10	2758	901	12	4762	2906	10	4299	2442	/	/	/	10	5840	3984	/	/	/	8
	6.75	1850	12	4212	2356	/	/	/	10	3749	1892	12	6444	4588	10	5290	3434	/	/	/	8
	6.75	2232	12	3745	1518	14	6114	3886	10	3282	1054	12	5977	3750	10	4823	2595	12	8210	5982	10
	6.75	2907	14	5289	3061	16	7926	5698	12	5152	2925	14	8338	6110	10	3998	1770	12	7385	5157	10
	6.75	3380	14	4711	2483	16	7348	5120	12	4574	2347	14	7760	5532	12	6806	4579	/	/	/	12A
	6.75	3920	14	4051	1823	16	6688	4460	12	3914	1687	14	7100	4872	12	6146	3919	14	10149	7921	12A
	6.75	4460	16	6028	3800	18	9125	6898	14	6440	4212	16	9986	7759	12	5486	3259	14	9489	7261	12A
	6.75	5852	18	7424	4194	20	10784	7554	16	8285	5055	18	12451	9221	14	7787	4558	16	12243	9013	12B
	6.75	6300	20	10236	5781	22	13937	9482	16	7737	3282	18	11903	7448	16	11696	7241	18	16930	12475	12C
	6.75	7380	20	8916	4461	22	12617	8162	18	10583	6128	20	15101	10646	16	10376	5921	18	15610	11155	12C
	6.75	8000	22	11859	4434	24	16050	8625	20	14343	6918	22	19321	11896	18	14852	7427	20	20528	13103	12D
6.75	9800	24	13850	6425	26	18258	10833	22	17121	9696	24	22757	15332	18	12652	5227	20	18328	10903	12D	
6.75	11600	26	16058	8633	28	20977	13552	24	20557	13132	26	26484	19059	22	22382	14957	/	/	/	12D	
8	8.75	2367	14	5949	3061	/	/	/	12	5812	2925	/	/	/	12	8045	5157	/	/	/	10
	8.75	2637	14	5619	2731	16	8256	5368	12	5482	2595	14	8668	5780	12	7715	4827	/	/	/	10
	8.75	2840	14	5371	2483	16	8008	5120	12	5234	2347	14	8420	5532	12	7466	4579	/	/	/	12A
	8.75	3380	14	4711	1823	16	7348	4460	12	4574	1687	14	7760	4872	12	6806	3919	/	/	/	12A
	8.75	4140	18	9516	3741	20	12876	7101	16	10377	4602	18	14543	8768	16	14336	8561	/	/	/	12C
	8.75	5220	18	8196	2421	20	11556	5781	16	9057	3282	18	13223	7448	16	13016	7241	/	/	/	12C
	8.75	5760	20	10896	5121	22	14597	8822	18	12563	6788	20	17081	11306	16	12356	6581	18	17590	11815	12C
	8.75	7100	22	12959	3334	24	17150	7525	20	15443	5818	22	20421	10796	20	21628	12003	/	/	/	12D
	8.75	8900	24	14950	5325	26	19358	9733	22	18221	8596	/	/	/	20	19428	9803	/	/	/	12D
	8.75	10700	26	17158	7533	28	22077	12452	22	16021	6396	24	21657	12032	20	17228	7603	22	23482	13857	12D
8.75	12931	30	24635	9908	22 TC	27470	12744	26	24857	10131	28	31473	16747	26	35283	20557	/	/	/	12E	
10	10.75	3500	16	7201	2057	18	10299	5155	14	7613	2469	16	11159	6016	14	10662	5518	/	/	/	12B
	10.75	4680	20	12216	5121	22	15917	8822	16	9717	2622	18	13883	6788	16	13676	6581	/	/	/	12C
	10.75	5300	22	15159	3334	24	19350	7525	20	17643	5818	/	/	/	18	18152	6327	/	/	/	12D
	10.75	6200	24	18250	6425	26	22658	10833	20	16543	4718	22	21521	9696	20	22728	10903	/	/	/	12D
	10.75	8800	28	24400	6307	30	29684	11591	26	29906	11814	28	36522	18430	24	32885	14793	/	/	/	12E
	10.75	11554	30	26318	8225	22 TC	29153	11061	28	33156	15064	/	/	/	26	36966	18874	/	/	/	12E
	10.75	14308	22 TC	25787	7695	24 TC	34169	16077	30	36896	18804	/	/	/	28	41913	23820	/	/	/	12E

### ETC Preload (End-to-Close Thrust)

Force required to fully seat the valve under operating conditions  
 Must be greater than  $[(\text{valve packing friction}) + (\text{valve seat friction}) + (\text{valve hydrostatic force})] \times [\text{safety factor}]$

### ETO (End-to-Open Thrust)

End-to-open; actuator available force at the end of the opening stroke  
 Must be greater than  $[\text{valve packing friction}]$

### BTO (Break-to-Open Thrust)

Break-to-open; available force to 'crack-open' the valve when the actuator is fully extended  
 Must be greater than  $[\text{valve packing friction}] + [\text{valve seat friction}]$

Stated thrust values are based on spring rates determined in accordance with ASTM A-125. Stated thrust values are for standard actuators only, if accessories are added, please consult factory.

Note - Consult Factory for larger actuators or Thrust values not shown here

# Standard Model: Fail-Open Data

Actuation Solutions and Systems for the World's Most Challenging Environments

Valve Stroke	Maximum Travel	ETO Preload	BTO	Available Force @ 60 psi				Available Force @ 80 psi				Available Force @ 100 psi				Spring Canister
				Bore	ETC	Bore	ETC	Bore	ETC	Bore	ETC	Bore	ETC	Bore	ETC	
(IN)	(IN)	(LBS)	(LBS)	(IN)	(LBS)	(IN)	(LBS)	(IN)	(LBS)	(IN)	(LBS)	(IN)	(LBS)	(IN)	(LBS)	(#)
2	2.75	300	976	6	523	7	1095	6	1073	7	1849	6	1623	7	2603	4
	2.75	400	1076	6	419	7	991	6	969	7	1745	6	1519	7	2499	4
	2.75	525	1201	7	861	8	1520	6	839	7	1615	6	1388	7	2369	4
	2.75	638	1314	7	744	8	1403	6	722	7	1498	6	1271	7	2252	4
	2.75	750	1426	8	1286	0		7	1380	8	2276	6	1154	7	2134	4
	2.75	1000	1523	8	1088	10	2632	7	1182	8	2078	7	1936	8	3067	6
	2.75	1180	1703	10	2433			8	1879	10	3974	7	1737	8	2868	6
	2.75	1360	1883	10	2234			8	1680	10	3776	7	1538	8	2669	6
	2.75	1540	2063	10	2035			8	1481	10	3577	8	2470	10	5118	6
3	3.75	550	1263	7	716	8	1375	7	1470	8	2365	7	2224	8	3355	6
	3.75	640	1353	8	1276	10	2820	7	1370	8	2266	7	2124	8	3255	6
	3.75	730	1443	8	1177	10	2721	7	1271	8	2166	7	2025	8	3156	6
	3.75	1000	1713	10	2422			8	1868	10	3963	7	1726	8	2857	6
	3.75	1180	1893	10	2223			8	1669	10	3764	7	1527	8	2658	6
	3.75	1513	2403	10	1659	12	3594	10	3200	12	5826	8	2094	10	4741	8
	3.75	1963	2853	12	3097	14	5384	10	2703	12	5329	10	4244	12	7561	8
	3.75	2188	3078	12	2848	14	5135	12	5080	14	8184	10	3995	12	7313	8
	3.75	2638	3528	14	4638			12	4583	14	7687	10	3498	12	6815	8
	3.75	3177	4246	14	3845	16	6391	12	3790	14	6894	12	6022	14	9943	10
4	4.75	820	1723	8	867	10	2411	7	961	8	1857	7	1715	8	2846	6
	4.75	910	1813	10	2312			8	1757	10	3853	7	1616	8	2747	6
	4.75	1090	1993	10	2113			8	1558	10	3654	7	1417	8	2548	6
	4.75	1400	2528	10	1521	12	3456	10	3062	12	5688	8	1956	10	4603	8
	4.75	1625	2753	12	3207	14	5494	10	2813	12	5440	8	1707	10	4354	8
	4.75	1963	3091	12	2834	14	5121	10	2440	12	5067	10	3981	12	7299	8
	4.75	2188	3316	12	2586	14	4873	12	4818	14	7922	10	3733	12	7050	8
	4.75	3042	4396	14	3679	16	6225	12	3624	14	6728	12	5856	14	9777	10
	4.75	3582	4936	16	5628			14	6131	16	9587	12	5259	14	9180	10

FOR LEGEND, SEE LAST PAGE OF FAIL-OPEN DATA

Note: it is the user's responsibility to ensure that final selection satisfies the application

Note: for forces other than shown, please consult factory

# Standard Model: Fail-Open Data

Actuation Solutions and Systems for the World's Most Challenging Environments

Valve Stroke	Maximum Travel	ETO Preload	BTO	Available Force @ 60 psi				Available Force @ 80 psi				Available Force @ 100 psi				Spring Canister
				Bore	ETC	Bore	ETC	Bore	ETC	Bore	ETC	Bore	ETC	Bore	ETC	
(IN)	(IN)	(LBS)	(LBS)	(IN)	(LBS)	(IN)	(LBS)	(IN)	(LBS)	(IN)	(LBS)	(IN)	(LBS)	(IN)	(LBS)	(#)
5	5.75	3177	4816	14	3215	16	5761	12	3160	14	6264	12	5392	14	9313	10
	5.75	3582	5221	16	5313			14	5816	16	9272	12	4944	14	8865	10
	5.75	4190	5829	16	4641	18	7632	14	5144	16	8600	14	8193	16	12558	12A
	5.75	4676	7052	18	6280	20	9523	16	7247	18	11306	14	6841	16	11206	12B
	5.75	5460	7836	18	5413	20	8657	16	6381	18	10440	14	5974	16	10339	12B
6	6.75	1400	3003	12	2931	14	5218	10	2537	12	5163	10	4078	12	7396	8
	6.75	1850	3453	12	2434	14	4721	10	2040	12	4666	10	3581	12	6898	8
	6.75	2232	4156	14	3944	16	6490	12	3889	14	6993	12	6122	14	10042	10
	6.75	2907	4831	14	3198	16	5744	12	3143	14	6247	12	5376	14	9296	10
	6.75	3380	5304	16	5221	18	8212	14	5724	16	9180	12	4853	14	8773	12A
	6.75	3920	5844	16	4625	18	7615	14	5128	16	8583	12	4256	14	8177	12A
	6.75	4460	6384	16	4028	18	7019	14	4531	16	7986	14	7580	16	11945	12A
	6.75	5852	8641	20	7767	22	11341	16	5491	18	9550	16	9449	18	14576	12B
	6.75	6300	10148	20	6102	22	9676	18	7885	20	12287	16	7785	18	12912	12C
	6.75	7380	11228	22	8482	24	12529	20	11094	22	15944	18	11718	20	17279	12C
	6.75	8000	14413	24	9008	26	13264	20	7573	22	12423	18	8198	20	13758	12D
	6.75	9800	16213	26	11274	28	16024	22	10434	24	15925	20	11769	22	17895	12D
6.75	11600	18013	26	9285	28	14035	24	13936	26	19711	22	15906	24	22842	12D	
8	8.75	2367	4861	14	3165	16	5711	12	3110	14	6214	12	5342	14	9263	10
	8.75	2637	5131	14	2867	16	5413	12	2812	14	5916	12	5044	14	8965	10
	8.75	2840	5334	14	2642	16	5188	14	5691	16	9147	12	4820	14	8740	12A
	8.75	3380	5874	16	4591	18	7582	14	5094	16	8550	12	4223	14	8143	12A
	8.75	4140	9128	18	3986	20	7230	16	4954	18	9013	16	8912	14	4547	12C
	8.75	5220	10208	20	6036	22	9610	18	7819	20	12221	16	7718	18	12845	12C
	8.75	5760	10748	20	5439	22	9013	18	7222	20	11624	16	7122	18	12249	12C
	8.75	7100	15413	24	7903	26	12158	20	6468	22	11318	20	12653	22	18779	12D
	8.75	8900	17213	26	10169	28	14919	22	9329	24	14820	20	10664	22	16790	12D
	8.75	10700	19013	26	8179	28	12929	24	12831	26	18606	20	8674	22	14800	12D
	8.75	12931	25649	22 TC	13434	24 TC	21527	28	17717	30	24641	26	21696	28	29839	12E

FOR LEGEND, SEE NEXT PAGE

Note: it is the user's responsibility to ensure that final selection satisfies the application

Note: for forces other than shown, please consult factory

# Standard Model: Fail-Open Data

Actuation Solutions and Systems for the World's Most Challenging Environments

Valve Stroke	Maximum Travel	ETO Preload	BTO	Available Force @ 60 psi				Available Force @ 80 psi				Available Force @ 100 psi				Spring Canister
				Bore	ETC	Bore	ETC	Bore	ETC	Bore	ETC	Bore	ETC			
(IN)	(IN)	(LBS)	(LBS)	(IN)	(LBS)	(IN)	(LBS)	(IN)	(LBS)	(IN)	(LBS)	(IN)	(LBS)	(IN)	(LBS)	(#)
10	10.75	3500	7942	18	5296	20	8540	16	6263	18	10322	14	5857	16	10222	12B
	10.75	4680	10808	20	5373	22	8946	18	7156	20	11558	16	7055	18	12182	12C
	10.75	5300	15513	22	3746	24	7793	20	6358	22	11207	18	6982	20	12543	12D
	10.75	6200	16413	24	6798	26	11053	22	10213	24	15704	20	11548	22	17674	12D
	10.75	8800	24425	30	12049	22 TC	14787	26	12623	28	19070	24	15755	26	23049	12E
	10.75	11554	27179	30	9005	22 TC	11743	28	16026	30	22950	24	12711	26	20005	12E
	10.75	14308	29933	24 TC	16792			28	12982	30	19906	26	16962	28	25105	12E

### ETO Preload (End-to-Open Thrust)

- End-to-Open; available spring force when the actuator is fully retracted
- Must be greater than [valve packing friction]

### ETC (End-to-Close Thrust)

- End-to-Close; actuator available force to seat valve
- Must be greater than  $([\text{valve packing friction}] + [\text{valve seat friction}] + [\text{hydrostatic force}]) \times [\text{safety factor}]$

### BTO (Break-to-Open Thrust)

- Break-to-Open; available force to 'crack-open' the valve when the actuator is fully extended
- Must be greater than  $([\text{valve packing friction}] + [\text{valve seat friction}]) \times [\text{safety factor}]$

*Note: it is the user's responsibility to ensure that final selection satisfies the application*

*Note: for forces other than shown, please consult factory*

# Actuator Dimensions: Standard & Compact Single-Stage

Actuation Solutions and Systems for the World's Most Challenging Environments

BORE	Cylinder Dimensions (in)						Weight (lbs)		ISO or MSS Mounting Pattern*	
	A	B	EE	LB	KK	MM	BASE	PER-IN	STD	OPT
6	1.75	1.50	¼	4.50	⅝-18	1.00	53	0.82	F/FA07	
7	1.75	1.50	⅜	4.00	⅝-18	1.00	55	0.97	F/FA07	
8	1.75	1.50	⅜	4.00	⅝-18	1.00	69	0.99	F/FA10	F/FA07
10	2.25	2.00	½	4.13	1-14	1.38	131	1.73	F/FA10	F/FA07
12	2.25	2.00	½	4.50	1-14	1.38	207	1.81	F/FA14	F/FA10
14	2.25	2.00	½	5.25	1-14	1.38	304	2.06	F/FA14	F/FA10
16	2.25	2.63	½	5.75	2¼-12	2.00	448	3.65	F/FA14	F/FA10
18	2.25	2.63	¾	5.75	2¼-12	2.00	560	3.76	F/FA16	F/FA14
20	2.25	3.13	¾	6.50	2¼-12	2.50	778	5.56	F/FA16	F/FA14
22	3.50	3.75	¾	7.50	2¼-12	3.00	1,031	7.19	F/FA25	F/FA16
24	3.50	3.75	¾	8.50	2¼-12	3.00	1,384	7.33	F/FA25	F/FA16
26	3.50	4.25	¾	9.50	2¼-12	3.50	1,841	9.24	F/FA30	F/FA25
28	3.50	4.25	¾	13.00	2¼-12	3.50	2,944	9.71	F/FA25	F/FA30
30	3.50	4.25	¾	13.00	2¼-12	3.50	3,320	9.85	F/FA25	F/FA30
32	3.50	4.75	1½	14.00	2¾-12	4.00	3,879	12.74	F/FA30	F/FA35
36	4.50	6.25	1½	20.00	4-12	5.50	7,051	20.62	F/FA30	F/FA35
42	4.50	6.25	1½	20.00	4-12	5.50	9,970	21.23	F/FA30	F/FA35

\* Assembly Weight FAIL CLOSE = Base# + (Per-IN# X STROKE) + FAIL CLOSE#

\* Assembly Weight FAIL OPEN = Base# + (Per-IN# X STROKE) + FAIL OPEN#

Canister Bore	AS Spring Canister Dimensions (in)							Weight (lbs)			
	CA (COMPACT MODEL)	CA (STANDARD MODEL)	CB	CC	CD	CE	CF	FAIL CLOSE (COMPACT MODEL)	FAIL OPEN (COMPACT MODEL)	FAIL CLOSE (STANDARD MODEL)	FAIL OPEN (STANDARD MODEL)
4	8.500	16.500	6.00	6.75	5.69	1/2-20	0.38	27	29	43	47
6	10.438	21.688	8.63	7.25	5.69	1/2-20	0.50	48	53	77	87
8	11.750	26.750	10.38	9.00	5.69	1/2-20	0.63	94	100	145	157
10	13.870	32.750	11.75	10.50	5.69	1/2-20	0.63	149	164	232	262
12A	17.250	40.750	15.75	13.50	9.50	3/4-10	0.88	285	343	490	605
12B	18.620	42.000	15.75	13.50	9.50	3/4-10	0.88	374	431	593	708
12C	18.500	40.500	15.75	13.50	9.50	3/4-10	0.88	391	449	609	724
12D	25.250	51.250	15.75	13.50	9.50	3/4-10	0.88	503	561	803	918
12E	29.400	60.500	15.75	13.50	9.50	3/4-10	0.88	606	664	1,020	1,135
16	26.213	54.613	19.75	17.50	13.50	3/4-10	0.88	597	647	1,194	1,244
22	28.673	67.923	25.75	23.50	19.50	3/4-10	0.88	1740	1800	3,480	3,540

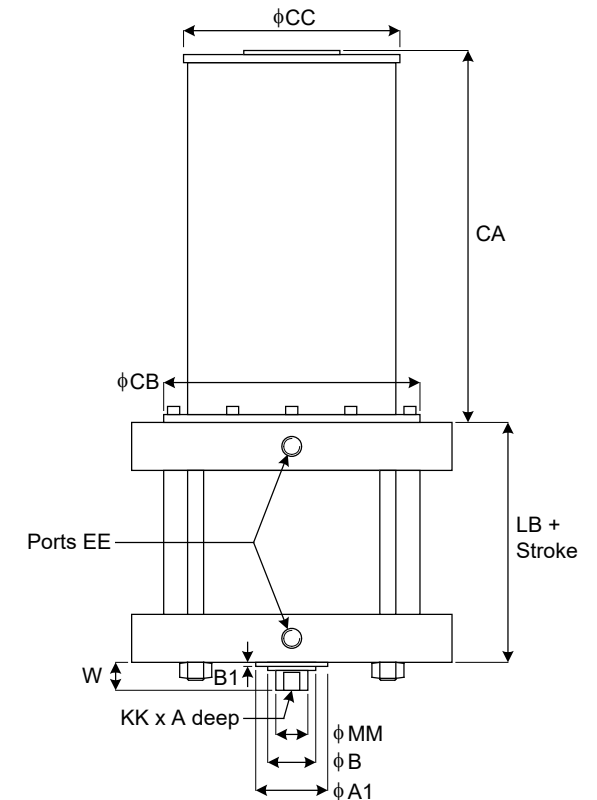
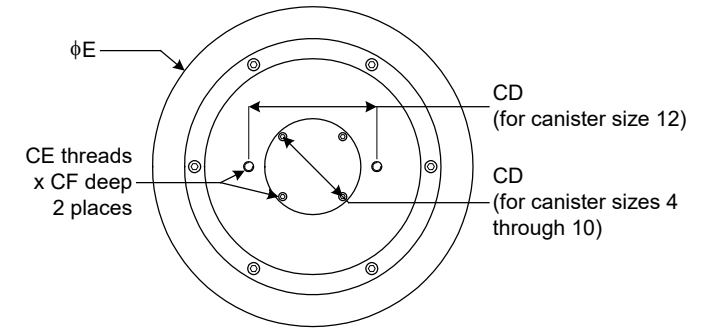

# Actuator Dimensions: Flange Mounting

Actuation Solutions and Systems for the World's Most Challenging Environments

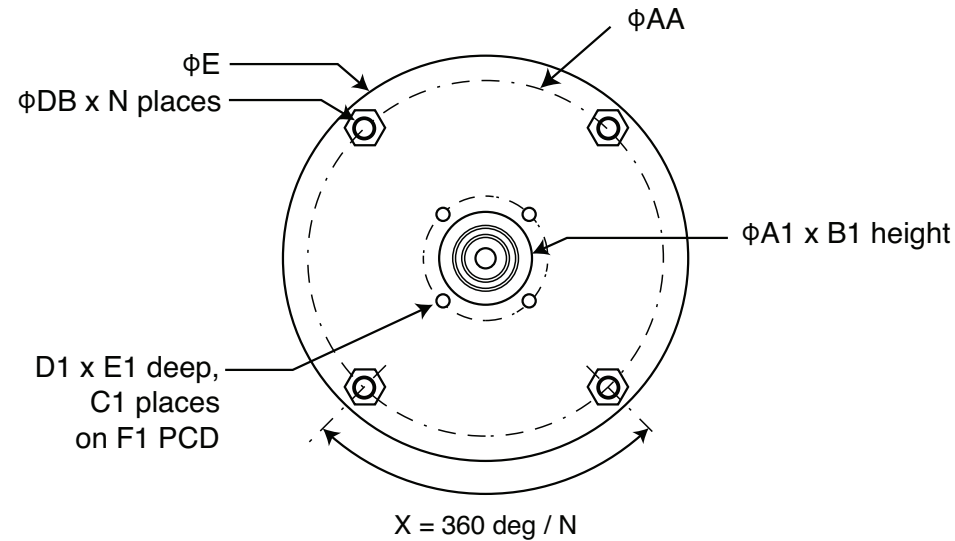

Cylinder Dimensions (in)				
Bore	DB	N	E	AA
6	1/2-20	4	8.13	7.00
7	5/8-18	4	9.25	8.13
8	5/8-18	4	10.38	9.13
10	3/4-16	4	12.75	11.25
12	3/4-16	4	15.75	13.38
14 & 14TC	7/8-14	4	17.25	15.50
16 & 16TC	7/8-14	6	19.88	17.88
18 & 18TC	7/8-14	6	22.25	20.00
20 & 20TC	7/8-14	10	24.50	22.50
22 & 22TC	7/8-14	10	26.50	24.50
24 & 24TC	7/8-14	10	28.50	26.50
26 & 26TC	7/8-14	12	31.75	28.75
28 & 28TC	7/8-14	14	33.63	30.63
30 & 30TC	7/8-14	14	35.63	32.63
32 & 32TC	1 1/8-12	8	37.63	34.63
36 & 36TC	1 1/8-12	12	40.00	39.03
42 & 42TC	1 1/8-12	12	50.50	47.50

MSS Flange Mounting Dimensions (in)							
MSS FLANGE	MAX. THRUST (lbs.)	A1	B1	C1	D1	E1	F1
FA07	4,500	2.166	0.120	4	5/16-18	11/16	2.750
FA10	9,000	2.312	0.120	4	3/8-16	11/16	4.000
FA14	25,000	3.750	0.160	4	5/8-11	13/16	5.500
FA16	35,000	5.000	0.190	4	3/4-10	1 1/8	6.500
FA25	50,000	6.000	0.190	8	5/8-11	1 1/8	10.000
FA30	75,000	7.000	0.190	8	3/4-10	1 1/8	11.750
FA35	140,000	8.500	0.190	8	1-8	1 1/4	14.000
FA40	230,000	9.000	0.320	8	1 1/4-7	1 1/2	16.000

ISO Flange Mounting Dimensions (in)							
ISO FLANGE	MAX. THRUST (lbs.)	A1	B1	C1	D1	E1	F1
F07	4,495	2.165	0.118	4	M8	7/16	2.755
F10	8,990	2.756	0.118	4	M10	5/8	4.016
F14	22,480	3.937	0.157	4	M16	3/4	5.512
F16	33,723	5.118	0.197	4	M20	7/8	6.496
F25	44,964	7.874	0.197	8	M16	7/8	10.000
F30	73,066	9.055	0.197	8	M20	7/8	11.732
F35	157,374	10.236	0.197	8	M30	7/8	14.016
F40	247,302	11.811	0.314	8	M36	7/8	15.984

# Actuator Dimensions: Standard & Compact Tandem

Actuation Solutions and Systems for the World's Most Challenging Environments

Tandem Cylinder Dimensions (in)							Weight (lbs)		ISO or MSS Mounting Pattern*	
BORE	A	B	EE	LB	KK	MM	BASE	PER-IN	STD	OPT
14	2.25	2.00	1/2	9.00	1-14	1.38	506	3.03	F/FA16	F/FA14
16	2.25	2.63	1/2	9.75	1 1/4-12	2.00	740	5.4	F/FA25	F/FA16
18	2.25	2.63	3/4	9.75	1 1/4-12	2.00	925	5.61	F/FA30	F/FA25
20	2.25	3.13	3/4	11.00	1 1/4-12	2.50	1,285	8.04	F/FA30	F/FA25
22	3.50	3.75	3/4	13.00	2 1/4-12	3.00	1,749	10.69	F/FA30	F/FA25
24	3.50	3.75	3/4	14.50	2 1/4-12	3.00	2,315	10.96	F/FA35	F/FA30
26	3.50	4.25	3/4	16.50	2 1/4-12	3.50	3,125	13.73	F/FA35	F/FA30
28	3.50	4.25	3/4	22.00	2 1/4-12	3.50	4,882	14.34	F/FA35	F/FA30
30	3.50	4.25	3/4	22.00	2 1/4-12	3.50	5,510	14.61	F/FA35	F/FA30
32	3.50	4.75	1 1/2	24.00	2 3/4-12	4.00	6,457	21.91	F/FA40	F/FA35
36	4.50	6.25	1 1/2	34.00	4-12	5.50	11,633	34.14	F/FA40	F/FA35
42	4.50	6.25	1 1/2	34.00	4-12	5.50	16,444	35.73	F/FA40	F/FA35

\* Assembly Weight FAIL CLOSE = Base# + (Per-IN# X STROKE) + FAIL CLOSE#

\* Assembly Weight FAIL OPEN = Base# + (Per-IN# X STROKE) + FAIL OPEN#

AS Spring Canister Dimensions (in)								Weight (lbs)			
Canister Bore	CA (COMPACT MODEL)	CA (STANDARD MODEL)	CB	CC	CD	CE	CF	FAIL CLOSE (COMPACT MODEL)	FAIL OPEN (COMPACT MODEL)	FAIL CLOSE (STANDARD MODEL)	FAIL OPEN (STANDARD MODEL)
4	8.500	16.500	6.00	6.75	5.69	1/2-20	0.38	27	29	43	47
6	10.438	21.688	8.63	7.25	5.69	1/2-20	0.50	48	53	77	87
8	11.750	26.750	10.38	9.00	5.69	1/2-20	0.63	94	100	145	157
10	13.870	32.750	11.75	10.50	5.69	1/2-20	0.63	149	164	232	262
12A	17.250	40.750	15.75	13.50	9.50	3/4-10	0.88	285	343	490	605
12B	18.620	42.000	15.75	13.50	9.50	3/4-10	0.88	374	431	593	708
12C	18.500	40.500	15.75	13.50	9.50	3/4-10	0.88	391	449	609	724
12D	25.250	51.250	15.75	13.50	9.50	3/4-10	0.88	503	561	803	918
12E	29.400	60.500	15.75	13.50	9.50	3/4-10	0.88	606	664	1,020	1,135
16	26.213	54.613	19.75	17.50	13.50	3/4-10	0.88	597	647	1,194	1,244
22	28.673	67.923	25.75	23.50	19.50	3/4-10	0.88	1740	1800	3,480	3,540

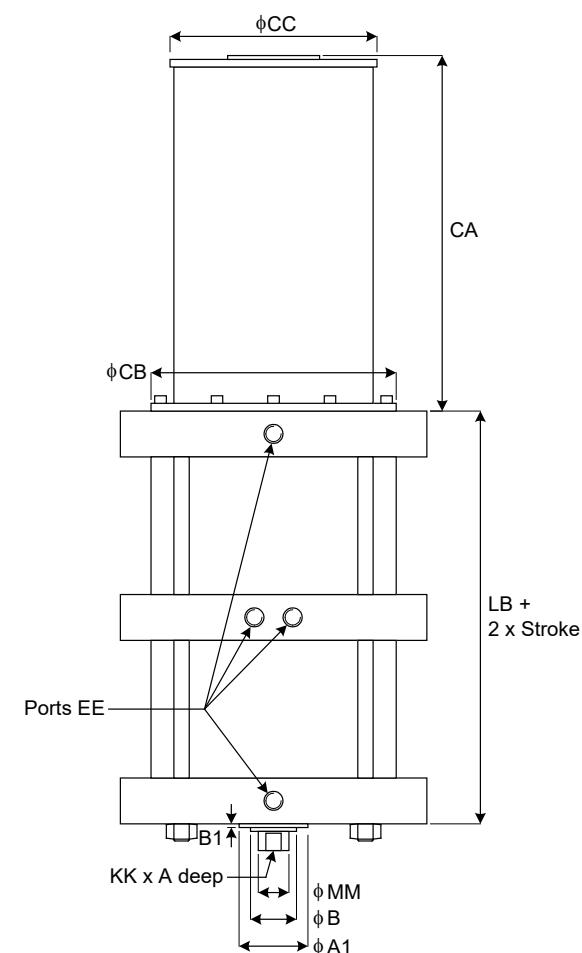
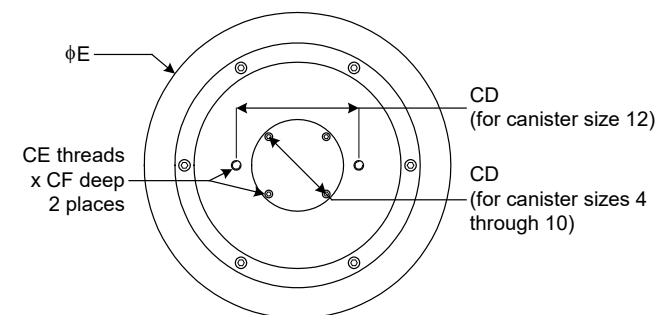

**Related materials**

Visit our website to download or request a printed catalogue.

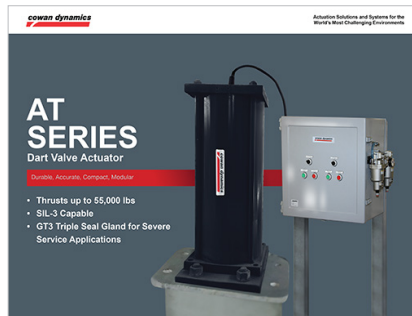

**Solutions Include:**

**Valve Actuators**

**Fail-Safe Systems**

**Digital Process Control Panels**

**Pneumatic Process Control Panels**

**For sales and technical information,  
Contact us at:**

**Head Office/Factory:**

6194 Notre Dame West  
Montreal, Quebec H4C 1V4  
TOLL-FREE: 855-341-3415  
info@cowandynamics.com

**f** /cowandynamics

**in** /company/cowan-dynamics

**You Tube** /cowandynamics

